

Up To Standards

Chrysler All-Wheel-Drive For Minivans, Part I

By Mike Weinberg

With the global competition for increased car sales, manufacturers are adding more options and more technology. In 1991, Chrysler introduced an all-wheel-drive system for the Dodge Caravan and Plymouth Voyager minivans. This system is found on minivans equipped with 3.3 liter V-6 engines, a 604 automatic transaxle and 15-inch wheels. Looking to create a safer vehicle in all weather conditions, many carmakers are offering all-wheel-drive systems. Unfortunately, very few consumers are educated properly in the operation and maintenance of the vehicles and even fewer will read the car owner's manual that resides in the glove box. All-wheel-drive is NOT the same as four-wheel-drive. All-wheel-drive is a fulltime system in which all four wheels are capable of transmitting power to the road. These ve-

hicles are not designed for off-road use as they do not have adequate ground clearance or skid plates to protect undercar components, and they do not have the low-reduction gearing necessary for off-road travel. The all-wheel-drive systems are designed to give better traction and cornering in adverse weather conditions and to give the manufacturer a technological advantage in the battle for sales.

The all-wheel-drive powertrain in the Chrysler minivans is a very sophisticated, complex system and in order to diagnose and repair it successfully, one must understand how the components operate and interact with one another (See Figure 1).

The 604 computer-controlled transaxle is modified to accept a Power Transfer Unit (PTU) that bolts to the

continues page 86

Put an End to Transfer Case Failures For Good!



**Extreme HD • AWD-To-Part-Time Conversions
Slip-Yoke Eliminator Kits • AWD Low-Range Lockups
AWD Viscous Eliminators**

JEEP TRANSFER CASES

All Jeep Transfer Cases are Remanufactured with the Latest O.E. Components

*Includes New Morse Chain

WRANGLER - YJ, TJ, NV231J, NV241J

CHEROKEE - XJ, NV231J, NV242J, NV249J

LIBERTY - KJ, NV231J, NV242J

GRAND CHEROKEE - ZJ, WJ, WK, NV140J, NV147J, NV231J, NV242J, NV245J, NV247J, NV249J

CHEROKEE/WAGONEER/J10 - NP208J, NP219J, NP228J, NP229J

Rockland Standard Gear can custom fit all of these transfer cases to any TJ, YJ, ZJ, WJ, XJ & KJ model

231J Command Trac
w/ Slip-Yoke Eliminator



247J & 249J AWD
Non-viscous - more MPG, less wear
Perfect for warmer climates
Retains safety of AWD



Up To Standards

**"AS" Body All-Wheel-Drive (AWD)
1991 All-Wheel-Drive Powerflow Chart**

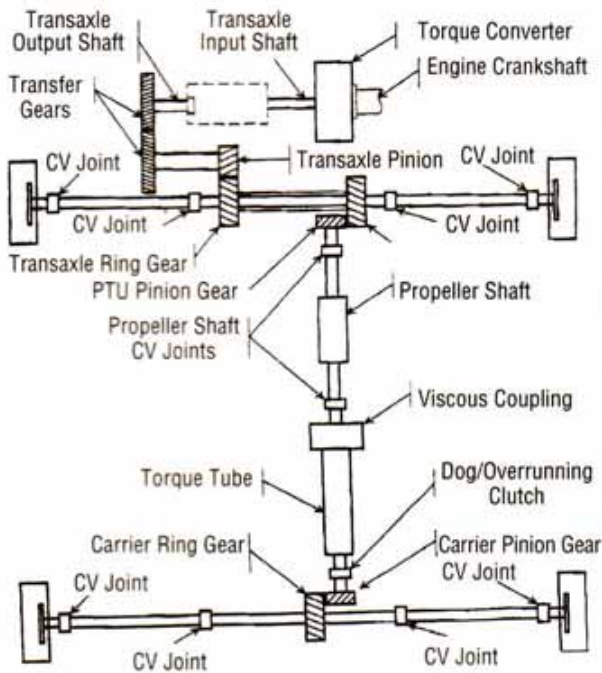

Figure 1

All-Wheel-Drive Component Overview

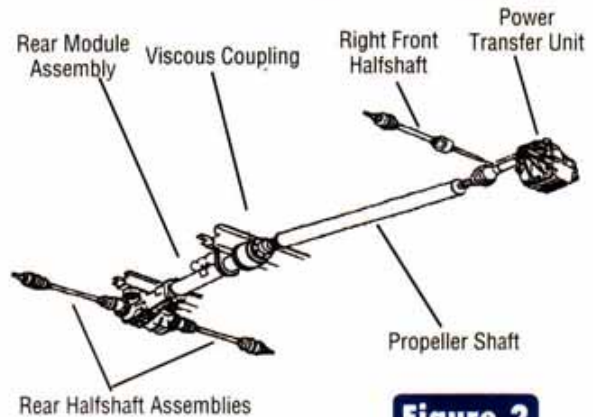

Figure 2

bad news as to the expense of these repairs, and they become very disenchanted with their choice of vehicles.

Other outside forces can create a nuclear meltdown on the aforementioned expensive components.

Example – with the viscous coupling, there are four differentials in this system. A wrong-size tire or tires,

continues next page

Sell The **BEST** Remanufactured Transfer Cases & Transmissions in the Business...

Switch To

ROCKLAND STANDARD GEAR!

Higher Quality, Service & Profits • Custom Units Our Specialty!

Put an End to Transfer Case Failures FOR GOOD!

• Extreme HD • AWD-To-Part-Time Conversions • Slip-Yoke Eliminator Kits • AWD Low-Range Lockups • AWD Viscous Eliminators



Jeep Transfer Cases



- 231J Command Trac
- 242J Select Trac
- 247J Pump Coupler AWD
- 249 J AWD

Rockland Standard Gear can custom fit all of these transfer cases to any TJ, YJ, ZJ, WJ, XJ & KJ model

Ford Transfer Cases



All Ford Transfer Cases are Remanufactured with the Latest O.E. Borg Warner Components

*Includes New Morse Chain
Models Available: 1350, 1354, 1356, 4404, 4405, 4406, 4407, 4410, 4411, 4416

GM Transfer Cases



All GM Transfer Cases are Remanufactured with the Latest O.E. Components with Updated Clutch Packs to Eliminate Chatter Problems

*Includes New Morse Chain
Models Available: 136GM, 226GM, 246GM, non-clutch style 231C-263GMXHD

Dodge Transfer Cases



All Dodge Transfer Cases are Remanufactured with O.E. Components

• Durango RT – Converts Full Time AWD to Select Trac or Command Trac
* Includes New Morse Chain
Models Available: 231D, 231DHD, 241DL, 241DHD, 242 Select Trac

RSG Has A Full Line Of Remanufactured Transmissions IN STOCK – READY TO SHIP!



- Ford M5R1 & M5R2
- 2F 5 & 6-Speeds (Ford Full-Series)
- AX5 & AX15 (Dodge & Jeep)
- New Venture 4500 (GM & Dodge)
- Call for other models!
- 3-Day Delivery – Same Price as Ground
- We Drop Ship & Handle Core Returns

CALL THE TC SPECIALISTS FOR LOWEST PRICES!

Call **1-800-227-1528**

Fax **1-877-774-3294** (TOLL FREE)

ONLINE AT www.pegear.com

Largest Inventory of Stock & Custom Applications

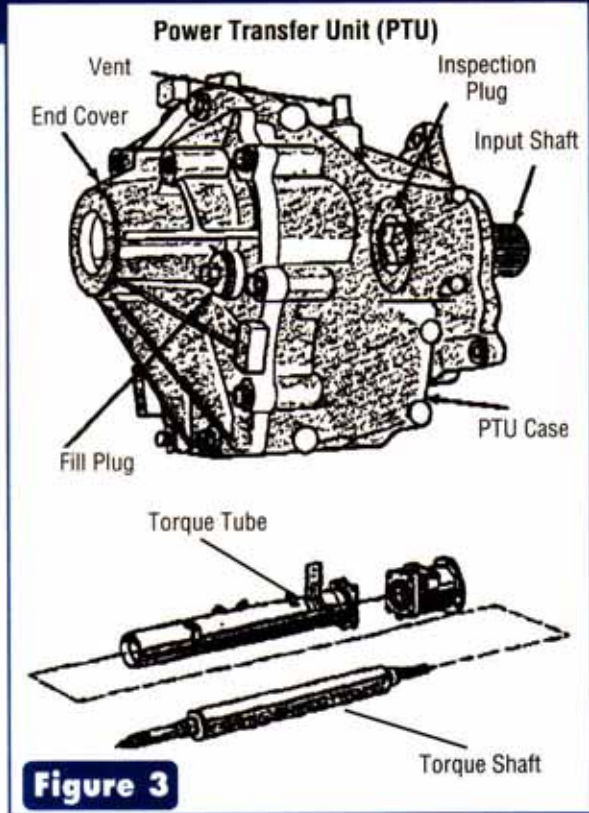

incorrect tire pressures or badly worn tires can cause big-time damage to the PTU, the viscous coupling or the other differentials.

Next month we are into Chrysler all-wheel-drive diagnostics. **TD**

